

Operating Manual



HL020 Miniature panel meter with analog input

Product features:

- Miniature panel housing 1.889 x 0.945 inch with mounting frame for 1.969 x 0.984 inch
- Analog input, configurable for voltage or current operation
- Display range -19 999 to 99 999
- Bright LED display with 5 digits
- Power supply 10 to 30 VDC
- Adjustable scaling factor and decimal place
- Minimum/ maximum memory
- Totalizing counter
- Adjustable over- and underflow range
- Latch input to freeze the display
- Protection class IP65 on front
- Simple parameterization and menu navigation via 2 buttons

Version:	Description:
HL02002a/hk/Dec06	Brochure format A5
HL02002b/hk/Aug07	Modification of temperature range
HL02002c/pp/Apr12	Corrected Specifications : Measuring cycle
HL020_02d_oi/ag/July15	- Safety instructions and legal Notices supplemented - Technical Specifications updated
HL020_02e_oi/ag	Correction of the temperature range
HL020_02f_oi/ cn	Error messages inserted
HL020_03_oi/ cn	Additional functions: totalizer and overflow and underflow range

Legal notices:
<p>All contents included in this manual are protected by the terms of use and copyrights of heinlanz GmbH. Any reproduction, modification, usage or publication in other electronic and printed media as well as in the internet requires prior written authorization by heinlanz GmbH.</p>

Table of Contents

1. Safety Instructions and Responsibility	4
1.1. General Safety Instructions	4
1.2. Use according to the intended purpose	4
1.3. Installation	5
1.4. Cleaning, Maintenance and Service Notes	5
2. Terminal Assignment	6
2.1. Inputs	6
2.1.1. Latch/Reset (Terminal 4)	6
2.1.2. Current input (Terminal 5)	6
2.1.3. Analog GND (Terminal 6)	6
2.1.4. Voltage input (Terminal 7)	6
3. Setting of the operation parameters	7
3.1. Selection of the displayed value	7
3.2. Setting the device parameters	7
4. Operational parameters	8
4.1. Input signal range (measuring range)	8
4.2. Measuring time	8
4.3. Decimal point setting	8
4.4. Minimum input signal	8
4.5. Display value for the lowest input signal	9
4.6. Maximum input signal	9
4.7. Display value for the highest input	9
4.8. Minimum value display	9
4.9. Minimum value reset	10
4.10. Maximum value display	10
4.11. Maximum value reset	10
4.12. Total sum counter (totalizer)	11
4.13. Totalizer decimal point setting	11
4.14. Factor	12
4.15. Skalierung	12
4.16. Totalizer reset	13
4.17. End of programming	13
5. Delivery includes:	13
7. Error messages	14
8. Dimensions	15
8.1. Mounting without use of add-on frames	15
8.2. Bezel 50 x 25 mm (1.969 x 0.984") for clip mounting	15
8.3. Bezel 50 x 25 mm (1.969 x 0.984") for screw mounting	15
9. Technical Specifications	16

1. Safety Instructions and Responsibility

1.1. General Safety Instructions

This operation manual is a significant component of the unit and includes important rules and hints about the installation, function and usage. Non-observance can result in damage and/or impairment of the functions to the unit or the machine or even in injury to persons using the equipment!

Please read the following instructions carefully before operating the device and observe all safety and warning instructions! Keep the manual for later use.

A pertinent qualification of the respective staff is a fundamental requirement in order to use these manual. The unit must be installed, connected and put into operation by a qualified electrician.

Liability exclusion: The manufacturer is not liable for personal injury and/or damage to property and for consequential damage, due to incorrect handling, installation and operation. Further claims, due to errors in the operation manual as well as misinterpretations are excluded from liability.

In addition the manufacturer reserve the right to modify the hardware, software or operation manual at any time and without prior notice. Therefore, there might be minor differences between the unit and the descriptions in operation manual.

The raiser respectively positioner is exclusively responsible for the safety of the system and equipment where the unit will be integrated.

During installation or maintenance all general and also all country- and application-specific safety rules and standards must be observed.

If the device is used in processes, where a failure or faulty operation could damage the system or injure persons, appropriate precautions to avoid such consequences must be taken.

1.2. Use according to the intended purpose

The unit is intended exclusively for use in industrial machines, constructions and systems. Non-conforming usage does not correspond to the provisions and lies within the sole responsibility of the user. The manufacturer is not liable for damages which has arisen through unsuitable and improper use.

Please note that device may only be installed in proper form and used in a technically perfect condition (in accordance to the Technical Specifications, see chapter [7](#)).

The device is not suitable for operation in explosion-proof areas or areas which are excluded by the EN 61010-1 standard.

1.3. Installation

The device is only allowed to be installed and operated within the permissible temperature range. Please ensure an adequate ventilation and avoid all direct contact between the device and hot or aggressive gases and liquids.

Before installation or maintenance, the unit must be disconnected from all voltage-sources. Further it must be ensured that no danger can arise by touching the disconnected voltage-sources.

Devices which are supplied by AC-voltages, must be connected exclusively by switches, respectively circuit-breakers with the low voltage network. The switch or circuit-breaker must be placed as near as possible to the device and further indicated as separator.

Incoming as well as outgoing wires and wires for extra low voltages (ELV) must be separated from dangerous electrical cables (SELV circuits) by using a double resp. increased isolation.

All selected wires and isolations must be conform to the provided voltage- and temperature-ranges. Further all country- and application-specific standards, which are relevant for structure, form and quality of the wires, must be ensured. Indications about the permissible wire cross-sections for wiring are described in the Technical Specifications (see chapter 7).

Before first start-up it must be ensured that all connections and wires are firmly seated and secured in the screw terminals. All (inclusively unused) terminals must be fastened by turning the relevant screws clockwise up to the stop.

Overvoltages at the connections must be limited to values in accordance to the overvoltage category II.

For placement, wiring, environmental conditions as well as shielding and earthing/grounding of the supply lines the general standards of industrial automation industry and the specific shielding instructions of the manufacturer are valid.

Please find all respective hints and rules on www.heinlanz.com
--> "[General EMC Rules for Wiring, Screening and Earthing]"

1.4. Cleaning, Maintenance and Service Notes

To clean the front of the unit please use only a slightly damp (not wet!), soft cloth. For the rear no cleaning is necessary. For an unscheduled, individual cleaning of the rear the maintenance staff or assembler is self-responsible.

During normal operation no maintenance is necessary. In case of unexpected problems, failures or malfunctions the device must be shipped for back to the manufacturer for checking, adjustment and reparation (if necessary). Unauthorized opening and repairing can have negative effects or failures to the protection-measures of the unit.

2. Terminal Assignment

(also printed to the top of the unit)

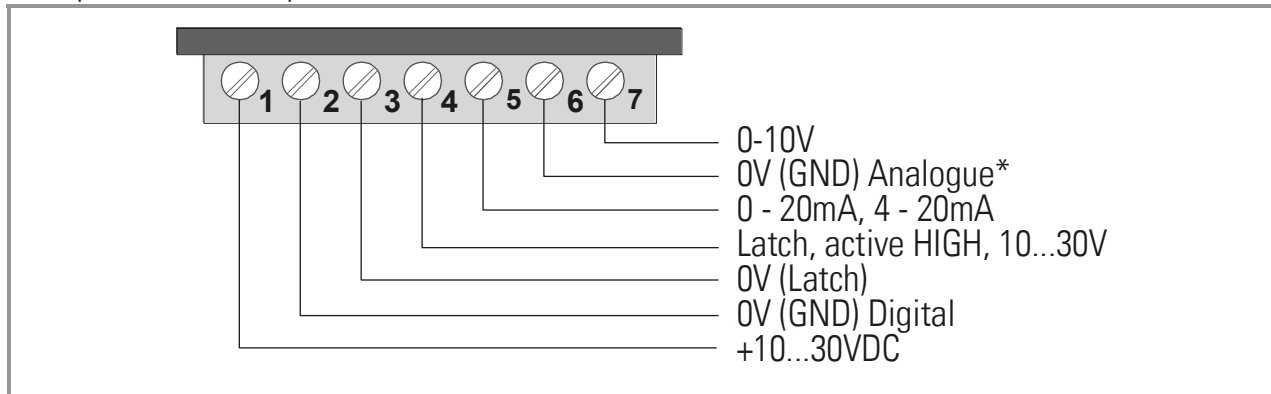

* Potential separated from GND digital/ power supply (terminal 2)

2.1. Inputs

2.1.1. Latch/Reset (Terminal 4)

The Latch/Reset input is a static input for display storage. If it is activated (pnp) with a 4...30 VDC input signal, the current measuring value is retained on the display until this input is released or its signal level sinks below 2 VDC.

The determination of the minimum and maximum value continues in the background. If an electrical reset is programmed for MIN, MAX, or for the Totalizer function, the function of the input changes to that of a reset input. It is therefore no longer possible to perform a Latch.

2.1.2. Current input (Terminal 5)

This is an analog current measurement input with reverse polarity protection and current limitation to 50 mA. The signal line carrying the analog + signal must be connected here.



This input is galvanically isolated to prevent interference signals due to the power supply. Therefore, the most negative signal line must be connected to the analog reference ground input for measurement.

2.1.3. Analog GND (Terminal 6)

The analog input at terminal 6 is an analog reference input. If no galvanic separation is required between the measuring circuit and the supply voltage, pin 2 or 3 must be connected to this terminal.

2.1.4. Voltage input (Terminal 7)

The voltage input at terminal 7 is an analog voltage measurement input. The signal line carrying the analog + signal must be connected here. In case of reverse polarity, the input is protected by a diode.

3. Setting of the operation parameters

3.1. Selection of the displayed value

<p>1. Selection of the displayed value:</p> <ul style="list-style-type: none"> • Only in the programming activated values are displayed 	<ul style="list-style-type: none"> • Pressing the right key allows switching between the display of the following measured value: <ul style="list-style-type: none"> ➤ Current measured value ➤ Minimum value ➤ Maximum value ➤ Totalizer value
--	---

3.2. Setting the device parameters

<p>Starting the programming mode</p> <ul style="list-style-type: none"> • Keep both front side keys depressed and switch the supply on • or, if the power supply is on, press both keys simultaneously for 5 seconds 	<p>The following message is displayed:</p> <div style="text-align: center; border: 1px solid black; padding: 5px; width: fit-content; margin: 0 auto;"> Prog </div> <ul style="list-style-type: none"> • As soon as the keys are released, the following message is displayed <div style="text-align: center; border: 1px solid black; padding: 5px; width: fit-content; margin: 0 auto;"> no </div> <ul style="list-style-type: none"> • Keep the left key depressed and press the right key, to abort the programming cycle • Press the right key to switch to <div style="text-align: center; border: 1px solid black; padding: 5px; width: fit-content; margin: 0 auto;"> YES </div>
<p>Switching to the first parameter:</p> <ul style="list-style-type: none"> • Keep the left key depressed and press the right key 	<ul style="list-style-type: none"> • As soon as the key is released, the display alternates every second between the menu title and the current menu item setting. • If a key is pressed, only the menu item setting remains displayed.
<p>Setting the parameter:</p>	<ul style="list-style-type: none"> • Press the right key to change the menu item setting by one value every time. • If numerical values are to be input (e.g. to set the factor), select the decade with the left key and then set the value with the right key.
<p>Switching to the next menu item</p>	<ul style="list-style-type: none"> • Keep the left key depressed and press the right key
<p>The end of the programming mode and the menu item „Endpro“</p>	<ul style="list-style-type: none"> • Selecting „Yes“ exits the programming menu and takes over (saving) the new values • If „No“ is selected, the programming routine restarts from the beginning, the last values set are maintained. They can now be modified or checked.

4. Operational parameters

The settable parameters of the device are listed below. Set these parameters as described in chapter "Setting of the operation parameters". The top symbol always corresponds to the factory setting.

4.1. Input signal range (measuring range)

rAnGE	range		
0.20mA	0.20mA	Measuring range between 2...20mA	
4.20mA	4.20mA	Measuring range between 4...20mA	
0.10V	0..10V	Measuring range between 0...10V	
2.10V	2..10V	Measuring range between 2...10V	

4.2. Measuring time

M-ti	M-ti		
0.5	0.5 sec	Measuring time 0,5 seconds	
0.1	0.1 sec	Measuring time 0,1 seconds	

4.3. Decimal point setting

dP.Act	dP.Act	Allows the setting of up to 4 decimal places	
0	0	No decimal place	
0.0	0.0	one decimal place	
0.00	0.00	two decimal places	
0.000	0.000	three decimal places	
0.0000	0.0000	Four decimal places	

4.4. Minimum input signal

Lo	Lo	This menu item allows extending or reducing the measuring range	
04.000	04.000	If the input signal becomes lower than the value programmed here for the measuring range,	
20.000	20.000	the display alternates between "Lo" and the measured value. Below the min. programmable measuring value, -1.9.9.9.9 is displayed to signal an underflow.	

4.5. Display value for the lowest input signal

LodiS	LodiS	The lowest input signal (depending on the setting of measuring range) is assigned to the set value. Adjustment area -19999...99999
-19999	-19999	Set the value that the device should display at 0V/ 0mA or 2V/4mA.
99999	99999	

4.6. Maximum input signal

hiCh	High	Extending or reducing the measuring range.
04000	04.000	If the input signal exceeds the value programmed here for the measuring range, the display alternates between "High" and the measured value. Above the max. programmable measuring range, 9.9.9.9.9 is displayed to signal an overflow.
20000	20.000	
	In case of an input voltage >10,8V there is an error, the message Error 4 is displayed.	

4.7. Display value for the highest input

hi.diS	Hi.diS	The highest input signal (depending on the setting of measure rage) is assigned to the set value. Adjustment are -19999 and 99999.
-19999	-19999	Set the value, which the device should display at 10V or 20mA.
99999	99999	

4.8. Minimum value display

Min	Min	Capture only within the set measuring range
YES	Yes	Minimum value is displayed. Right front button switches between „Act“, „Min“ und „Max“
no	no	Minimum value display is not recorded. The next and menu item is skipped.

4.9 Minimum value reset

rMin	rMin	Electrical reset by RESET input and manual reset by RESET button (with red key) possible. The minimum value is set to the current measured value.
MA.EL	MA.EL	Manual reset and electrical reset is possible
no.rES	no.rES	No rest of the minimum value possible
EL.rES	ELrES	Electrical reset only
MA.rE	MA.rE	Manual reset only



4.10. Maximum value display

MAX	MAX	Capture only within the set measurement range
YES	Yes	Maximum value is displayed. Right front button switches between „Act“, „Min“ und „Max“
no	no	Maximum value display is not recorded. The next and menu item is skipped.





4.11. Maximum value reset

rMAX	rMAX	Electrical reset by RESET input and manual reset by RESET button (with red key) possible. The maximum value is set to the current measured value.
MA.EL	MA.EL	Manual reset and electrical reset is possible
no.rES	no.rES	No rest of the maximum value possible
EL.rES	ELrES	Electrical reset only
MA.rE	MA.rE	Manual reset only

4.12 Total sum counter (totalizer)

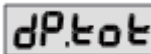
	totAL	The totalizer adds the current measured value every second. Totalizing only within the set measuring range
	no	Measured value totalizing switched off
	Yes	Measured value totalizing switched on. In case of counter over or underflow (>99999 or <-19999), the display flashes every second. In case of values >99999, the counter goes on counting and loses no value until reaching the internal counter value 199999. When the internal counter value 199999 is reached, no more values are added. The display goes on flashing every second, but the value remains 99999. In the negative direction, when it reaches <-19999, the value stops immediately and flashes every second. No leading zero blanking in case of overflow.



4.13 Totalizer decimal point setting

	dP.tot	The decimal point for the display can also be programmed for the sum (totalizer value). This has no effect on the display accuracy.
	0	No decimal place
	0.0	one decimal place
		two decimal places
		three decimal places
	0.0000	four decimal places









Sufficiently digits should be reserved for the display of the expected sum, as the sum stops at 19999 and the measuring result thus gets lost. If the 5-digit display is not sufficient, the "Factor" and the "Scaler" allow adjusting the sum accordingly.

4.14 Factor

FActo	FActo	The displayed totalizer value can be adapted optimally for the measuring task thanks to the factor. If for example the current measured value must be displayed in small units such as grams, but the result of the sum must be displayed in kilograms or tons, input the corresponding factor (multiplier):
	0.0001	Select the decade with the left key and set a factor between 0.0001 and 9.9999 with the right key.
	9.9999	
 Note: Factor and scaling only affect the totalizer. Total scaling = Factor x Scaling!		

4.15 Skalierung

ScALE	ScALE	Scaling allows extending the display range for the totalizer or reducing it for a very fine setting. Select the required scale with the right key: 1 is the factory setting.
	1	
	0.1	
	0.01	
	0.001	
	0.0001	
 Note: Factor and scaling only affect the totalizer. Total scaling = Factor x Scaling!		

4.16 Totalizer reset

r.tot	r.tot	There are four possibilities to reset the totalizer. This setting affects the function of the Latch/Reset input.
MA.EL	MA.EL	Manual reset (with red key) and electrical reset is possible. The MPI input operates as a RESET input.
no.rES	no.rES	No reset possible. The Latch/Reset input operates as a LATCH input. The current value displayed is frozen.
EL.rES	ELrES	Electrical reset only. The reset key is disabled. The Latch/Reset input operates as a RESET input.
MA.rE	MA.rE	Manual reset only. The Latch/Reset input operates as a LATCH input. The current value displayed is frozen.

4.17 End of programming

EndPro	EndPro	
no	no	The programming routine is performed once more. The value settings can be checked and modified.
YES	Yes	The programming routine ends and all set values are taken over as new parameters. The device is ready for operation.

5. Delivery includes:

- Digital display
- Panel mounting clip
- Bezel for screw mount with panel cut out 50 x 25mm
- Bezel for clip mount with panel cut out 50 x 25mm
- Sealing
- 1 sheet with self adhesive stickers (engineering units)

6. Error messages

Error code	Meaning	What is to do:
Err 0	Error/Defect in A/D part	Please send in devices for verification
Err 1	Invalid value (during programming)	Check programming
Err 2	LoLim<HiLim (during programming)	Check programming
Err 3	Error/Defect in EEPROM	Please send in devices for verification
Err 4	Analogue input signal exceeds the valid measuring range.	Check input signal and programming
Err 5	Error/Defect in EEPROM. Device not matched	Please send in devices for verification

7. Dimensions

7.1. Mounting without use of add-on frames

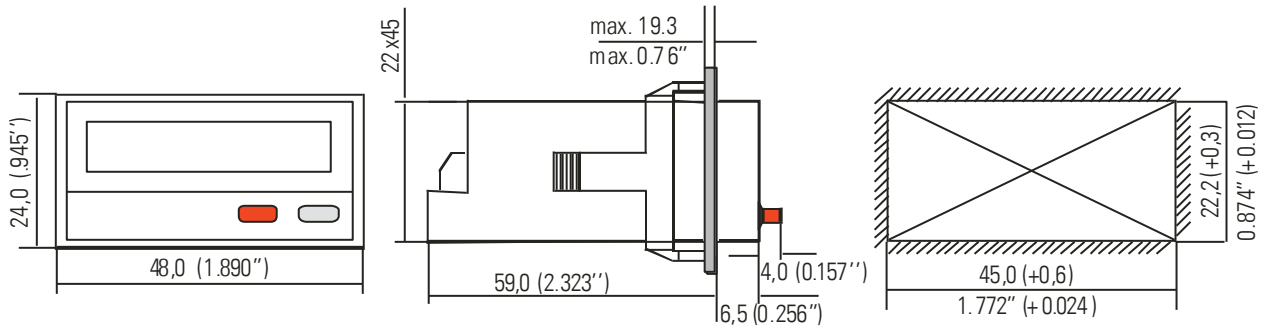

7.2. Bezel 50 x 25 mm (1.969 x 0.984") for clip mounting

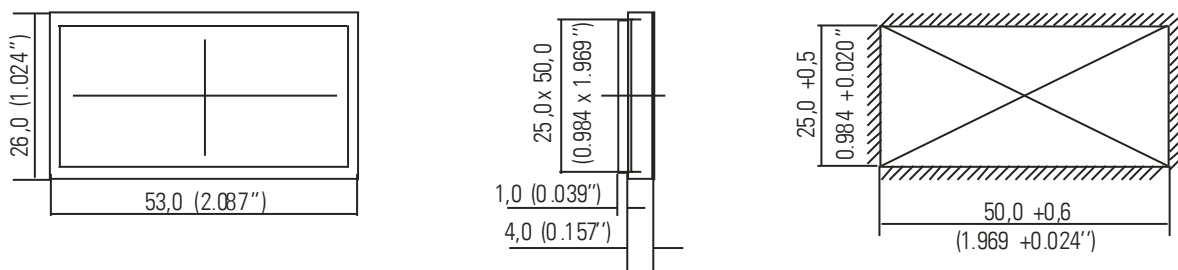

7.3. Bezel 50 x 25 mm (1.969 x 0.984") for screw mounting

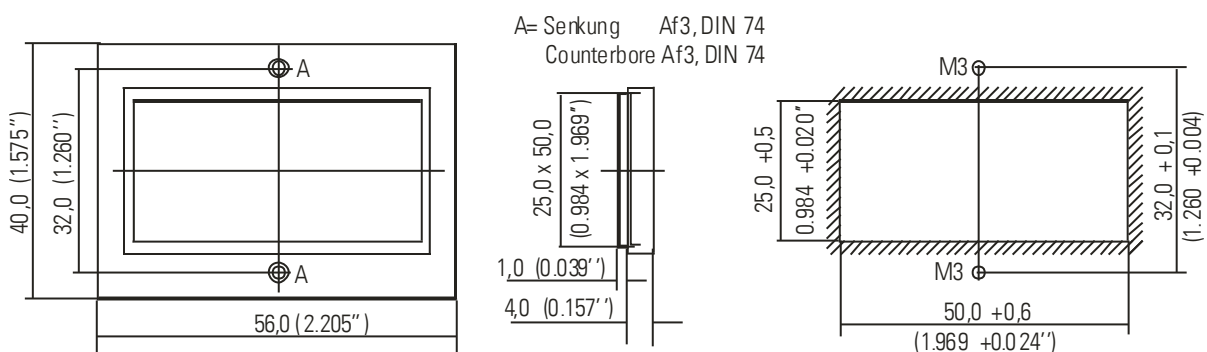

8. Technical Specifications

Technical Specifications:		
Power supply:	Input voltage:	10 ... 30 VDC
	Protection circuit:	reverse polarity protection
	Consumption:	max. 50 mA
	Connections:	screw terminal, 1.5 mm ² / AWG 16
Analog input:	Resolution:	14 Bit
	Voltage input:	0 ... 10 V / 2 ... 10 V
	Internal resistance:	R _i ≈ 1 MΩ
	mA input:	0 ... 20 mA / 4 ... 20 mA
	Internal resistance:	R _i ≈ 100 Ω
	Voltage drop:	max. 2 V at 20 mA
Control input:	Function:	display hold / latch
	Characteristic:	PNP, active high
	Signal levels:	LOW = 0 ... 2 V, HIGH = 4 ... 30 V
Accuracy:	Entire measuring range :	< 0.1 %, +/- 1 Digit (at 20° C / 68 °F ambient temperature)
	Temperature drift:	< 70 ppm/K
	Measuring time:	0,1s / 0,5s
Display:	Type:	5 digit LED, red
	Digit height:	8 mm / 0.3149 inch
	Range:	-19999 ... 99999
Housing:	Material:	plastic
	Mounting:	panel
	Dimensions:	cut out (w x h): 45 x 22 mm / 1.772 x 0.866 inch outer dimensions (w x h x d): 48 x 24 x 59 mm / 1.889 x 0.945 x 2.323 inch
	Miscellaneous:	additional bezels for clip or screw mounting are included in the delivery
	Protection class:	front: IP 65 / rear: IP20
	Weight:	approx. 50 g
Ambient temperature:	Operation:	-20°... + 65° C / -4° ... 141° F (not condensing)
	Storage:	-25°... + 70° C / -13° ... 158° F (not condensing)
Conformity & standards:	EMC 2004/108/EC:	EN 61000-6-2, EN 61000-6-3, EN 61000-6-4
	RoHS 2011/65/EU:	EN 50581